



A1 PREMIUM



gaviota
The Sun & Shutter Specialists

A1 PREMIUM



- Toldo frontal extensible de brazos apto para cubrir hasta 18 m², especialmente diseñado para ventanas y que puede ser aplicado en otras estructuras.
- Ideal para grandes dimensiones.

- Extendible front awning with arms able to cover up to 18 m² specially designed for windows and that can be applied to other structures.
- Ideal for large dimensions.

- Store frontal extensible adapté pour couvrir jusqu'à 18 m², spécialement conçu pour fenêtres et pouvant être appliqué à d'autres structures.
- Idéal pour les grandes dimensions.

- Tenda da sole frontale estensibile con bracci adatti a coprire superfici fino a 18 m², progettata per finestre ma può essere applicata anche su altre strutture.
- Ideale per grandi dimensioni.

Pensado para instalar en

Designed for installation in • Pensé pour installer en • Adatto all'installazione in



Sujeción

Fastening • Fixation • Fissaggio



Recomendado hasta

Recommended for up to • Conseillé jusqu'à • Consigliato fino a

<p>5,00 línea x 3,50 salida (m) 5,00 width x 3,50 projection (m) 5,00 largeur x 3,50 projection (m) 5,00 larghezza x 3,50 sporgenza (m)</p>	<p>6,00 línea x 3,00 salida (m) 6,00 width x 3,00 projection (m) 6,00 largeur x 3,00 projection (m) 6,00 larghezza x 3,00 sporgenza (m)</p>
--	--

Acabados

Finishes • Finitions • Rifiniture

GEOMET® 321

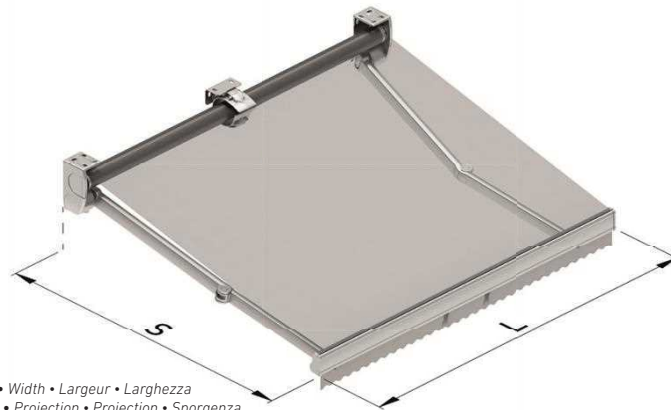

L = Línea • Width • Largeur • Larghezza
S = Salida • Projection • Projection • Sporgenza

Se distingue por

Distinguished by • Est différencié par • Caratteristiche

- Brazo articulado Premium de gran resistencia y con sistema de tensión interna.
- Adaptable a cajón Spiral Premium y tejadillo V2.
- Cuidada estética en todos sus componentes.
- Facilidad de instalación.
- Premium articulated arm of great resistance with internal tension system.
- Suitable for Spiral Premium box and V2 flat hood.
- Great care in the design of all its components.
- Easy to install.
- Bras articulé Premium de grande résistance avec système de tension interne.
- Adaptable à caisson Spiral Premium et auvent V2.
- Esthétique soignée de tous les composants.
- Installation facile.
- Braccio articolato Premium dotato di grande resistenza con sistema di tensione interna.
- Adattabile al cassetto Spiral Premium e tettuccio V2.
- Aspetto raffinato in tutte le sue componenti.
- Facilità di installazione.

Dimensiones

Measurements • Dimensions • Dimensioni

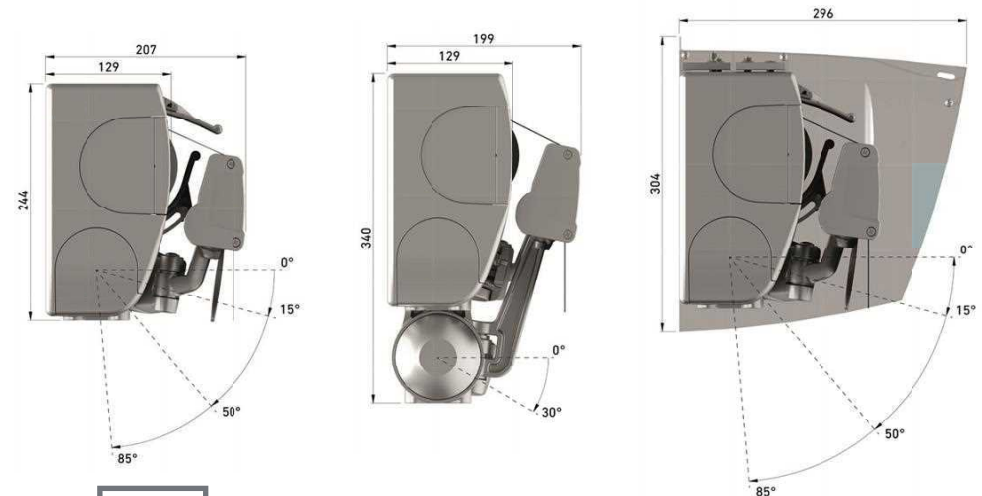

Compatibilidad

Compatibility • Compatibilità • Compatibilità



Brazos Premium
Premium Arms
Bras Premium
Bracci Premium

Brazos Concept
Arms Concept
Bras Concept
Bracci Concept

Cruce de brazos
Crossed arms
Croisement des bras
Bracci a incrocio



Conjunto y despiece con máquina dentro

Exploded view of set with inside gear

Vue éclatée des composants avec treuil dedans

Soluzione di montaggio e vista in spaccato con arganello interiore

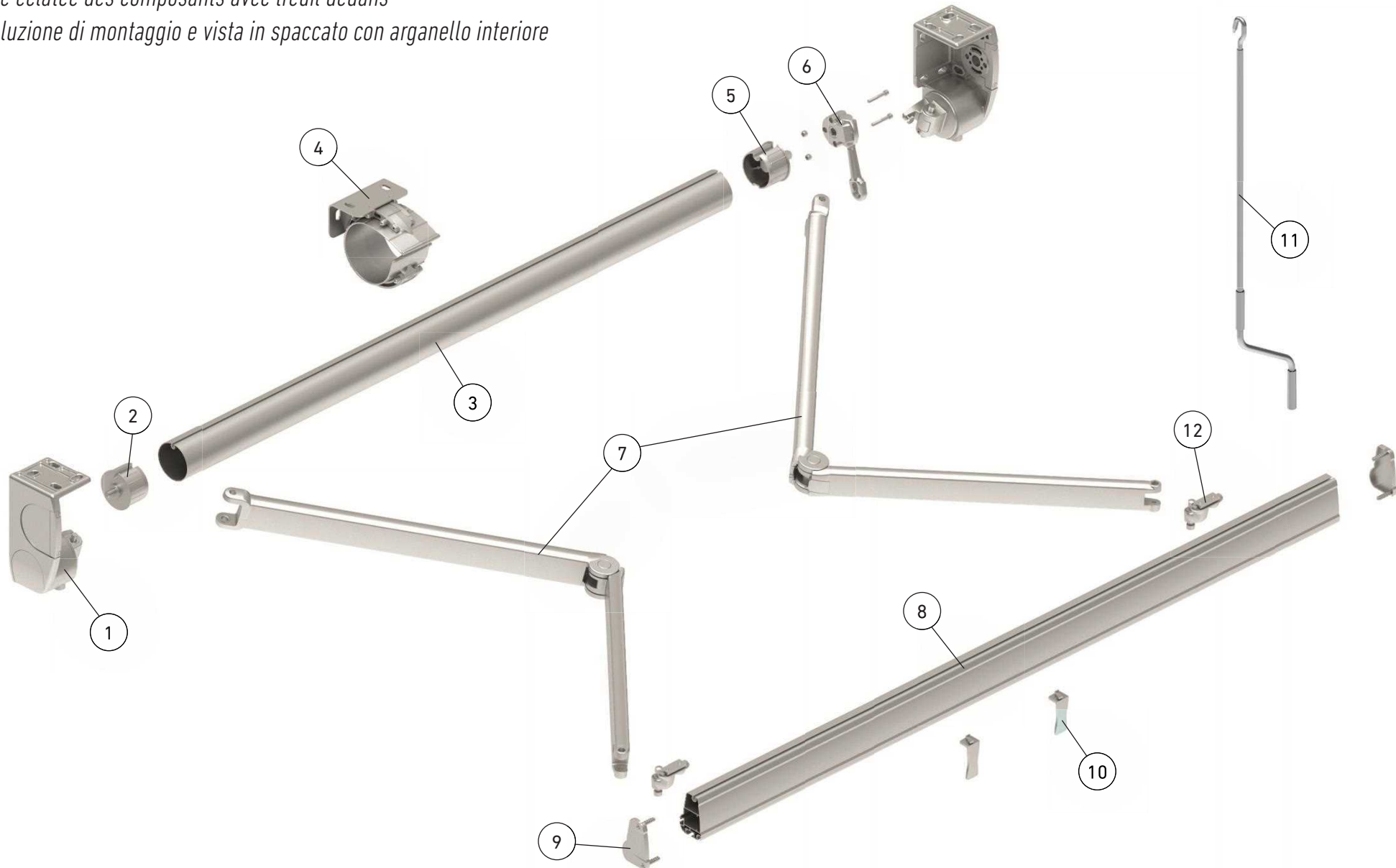

Ejemplo para montaje A1 Premium con máquina dentro, 6,00 m x 3,00 m (Línea x Salida). Color blanco. Eje Ø78.
Example for mounting A1 Premium with gear inside, 6,00 m x 3,00 m (Width x Projection). White colour. Axis Ø78.
Exemple pour montage A1 Premium avec treuil dedans, 6,00 m x 3,00 m (Largeur x Projection). Couleur blanc. Axe Ø78.
Esempio montaggio A1 Premium con arganello interiore, 6,00 m x 3,00 m (Larghezza x Sporgenza). Colore bianco. Rullo Ø78.

	Descripción • Description Description • Descrizione	Código • Code Code • Codice	Cantidad • Quantity Quantité • Quantità
1	Juego de soportes A1 Premium • Set of Premium A1 supports • Jeu de supports A1 Premium • Kit supporti A1 Premium	80081813	1
2	Casquillo punto espárrago redondo Ø78 ranurado • Ø78 cap with round pivot • Tourillon mâte côté opposé sortie ronde Ø78 • Calotta perno tondo Ø78	80020043	1
3	Tubo ranurado galvanizado ojiva Ø78 • Galvanized round tube with ogive Ø78 • Tube rond à gorge galvanisé Ø78 • Rullo nervato con ogiva Ø78	80030022	6 m
4	Soporte central lira a pared/techo, regulable con tornillos de anclaje y fijación para sujeción de tubo y lona • Lyre type central wall/ceiling support, adjustable with fixing screws for tube and fabric • Support central lyre mur/coulé, réglable avec boulons d'ancrage et fixation pour tube et toile • Supporto a parete centrale lira A1 Premium	80081697	1
5	Casquillo máquina espárrago cuadrado Ø78 ranurado • Ø78 driving cap with squared pivot • Tourillon mâte côté manoeuvre sortie carrée Ø78 rainuré • Calotta perno quadro Ø78	80020032	1
6	Máquina Gel 1/11 cáncamo 120 pasante • Gel gear 1/11, 120 mm eye, long screw • Treuil Gel 1/11 anneau 120 mm sans vis • Arganello Gel 1/11 occhio L=120 fori passante	80010348	1
7	Juego de brazos invisibles Premium • Set of Premium retractable arms • Jeu de bras invisibles Premium • Kit bracci invisibili Premium	80080845	1
8	Perfil terminal Bambu 3 • Bambu 3 frontal profile • Profil barre de charge Bambu 3 • Profilo terminale Bambu 3	80050334	6 m
9	Juego de tapas perfil Bambu 3 • Set of caps for Bambu 3 • Jeu d'obturateurs pour Bambu 3 • Kit tappi profilo terminale Bambu 3	80050340	1
10	Pivote tope barra de carga A1 (opcional) • Stopper pivot for A1 charge profile (optional) • Pivot arrêt barre de charge A1 (facultatif) • Ferma braccio per barra terminale (opzionale)	80081800	2
11	Manivela 1,50 blanca • 1,50 white handcrank • Manivelle crochet 1,50 blanc • Asta gancio 1,50 bianca	80090010	1
12	Juego de regletas inferiores • Set of lower adjustments • Fixations bras/barre de charge inférieure • Set squadrette fissaggio inferiore	80080885	1



A1 PREMIUM

arandes
protecció solar

Conjunto y despiece con motor

Exploded view and set with motor

Vue éclatée des composants avec moteur

Soluzione di montaggio e vista in spaccato con motore

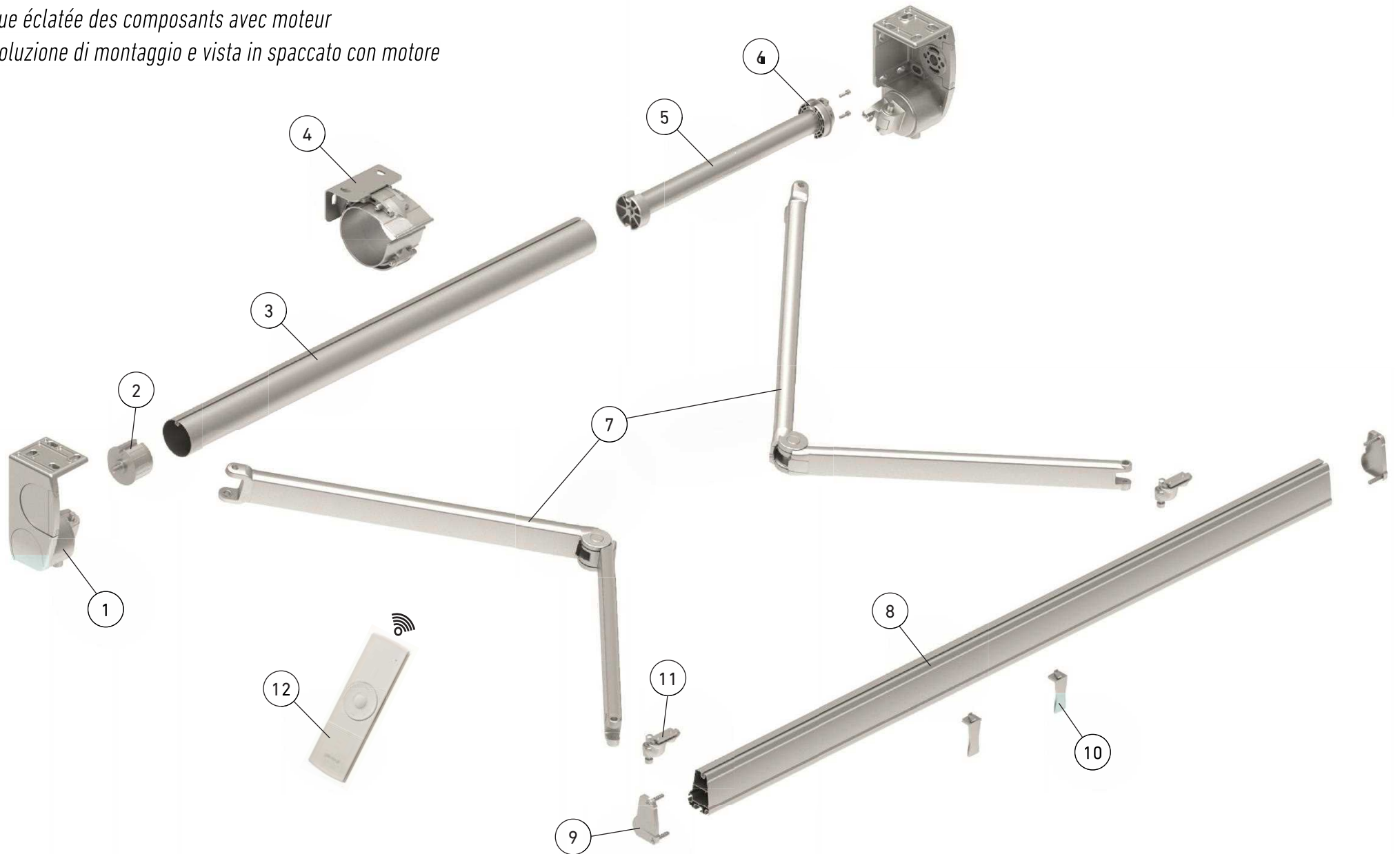

Ejemplo para montaje A1 Premium con motor, 6,00 m x 3,00 m (Línea x Salida). Color blanco. Eje Ø78.
Example for mounting A1 Premium with motor, 6,00 m x 3,00 m (Width x Projection). White colour. Axis Ø78.
Exemple pour montage A1 Premium avec moteur, 6,00 m x 3,00 m (Largeur x projection). Couleur blanc. Axe Ø78.
Esempio montaggio A1 Premium con motore, 6,00 m x 3,00 m (Larghezza x Sporgenza). Colore bianco. Rullo Ø78.

	Descripción • Description Description • Descrizione	Código • Code Code • Codice	Cantidad • Quantity Quantité • Quantità
1	Juego de soportes A1 Premium • Set of Premium A1 supports • Jeu de supports A1 Premium • Kit supporti A1 Premium	80081813	1
2	Casquillo punto espárrago redondo Ø78 ranurado • Ø78 cap with round pivot • Tourillon mâte côté opposé sortie ronde Ø78 • Calotta perno tondo Ø78	80020043	1
3	Tubo ranurado galvanizado ojiva Ø78 • Galvanized round tube with ogive Ø78 • Tube rond à gorge galvanisé Ø78 • Rullo nervato con ogiva Ø78	80030022	6 m
4	Soporte central lira a pared/techo, regulable con tornillos de anclaje y fijación para sujeción de tubo y lona • Lyre type central wall/ceiling support, adjustable with fixing screws for tube and fabric • Support central lyre mur/coulé, réglable avec boulons d'ancrage et fixation pour tube et toile • Supporto a parete centrale lira A1 Premium	80081697	1
5	Motor Cross Ø45 50/12 • Cross motor 045 50/12 • Moteur Cross Ø45 50/12 • Motore Cross Ø45 50/12	60050153	1
6	Juego de coronas para eje Ø78 Serie 45 • Set of adapters for Ø78 tube, 45 Series • Jeu de couronnes pour axe Ø78 Série 45 • Kit corone per rullo Ø78 Serie 45	60070060	1
7	Juego de brazos invisibles Premium • Premium set of retractable arms • Assortiment de bras invisibles Premium • Kit bracci invisibili Premium	80080845	1
8	Perfil terminal Bambu 3 • Bambu 3 profile terminal • Perfil terminal Bambu 3 • Profilo terminale Bambu 3	80050334	6 m
9	Juego de tapas perfil Bambu 3 • Set of caps for Bambu 3 • Jeu d'obtérateurs pour Bambu 3 • Kit tappi profilo terminale Bambu 3	80050340	1
10	Pivote tope barra de carga A1 (opcional) • Stopper pivot for A1 charge profile (optional) • Pivot arrêt barre de charge A1 (facultatif) • Ferma braccio per barra terminale (opzionale)	80081800	2
11	Juego de regletas inferiores • Set of lower adjustments • Fixations bras/barre de charge inférieure • Set squadrette fissaggio inferiore	80080885	1
12	Emisor 1 canal Cross • Cross channel emitter 1 • Émetteur 1 canal Cross • Trasmittitore 1 canale Cross	60090136	1

Ejemplo de montaje con tejadillo, 6,00 m (Línea). Color blanco. • *Example of mounting with flat hood, 6,00 m (Width). White colour.*
Exemple de montage avec auvent 6,00 m (Largeur). Couleur blanc. • *Esempio di montaggio con tettuccio 6,00 m (Larghezza). Colore bianco.*

Descripción • Description
 Description • Descrizione

Código • Code
 Code • Codice

Cantidad • Quantity
 Quantité • Quantità

- ① **Tejadillo monoblok V2** • *V2 monobloc flat hood* • *Auvent monoblok V2* • *Monoblok tettuccio V2*
- ② **Juego tapas tejadillo V2 grandes** • *Set of big flat hood caps V2* • *Assortiment couvercles auvent V2 grands* • *Kit tappi tettuccio V2 grandi*
- ③ **Juego regletas tejadillo para soporte extrusión con tornillos de ensamblaje** • *Set of hood mounting plate for extruded upper support, with white caps*
Jeu de fixations d'auvent pour support extrudé supérieur avec vis d'assemblage blancs • *Kit piastrine tettuccio per supporto estrusione con viti d'assemblaggio*
- ④ **Soporte superior tejadillo extrusión** • *Extrusion flat hood upper support* • *Support supérieur auvent extrusion* • *Supporto superiore tettuccio estrusione*

80081305	7 m
80081321	1
80080354	6
80080192	6

Opción con tejadillo

Option with flat hood
Option avec auvent
Opzione con tettuccio

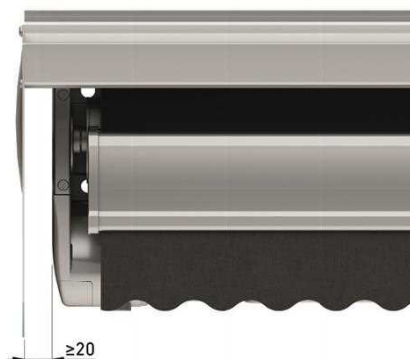
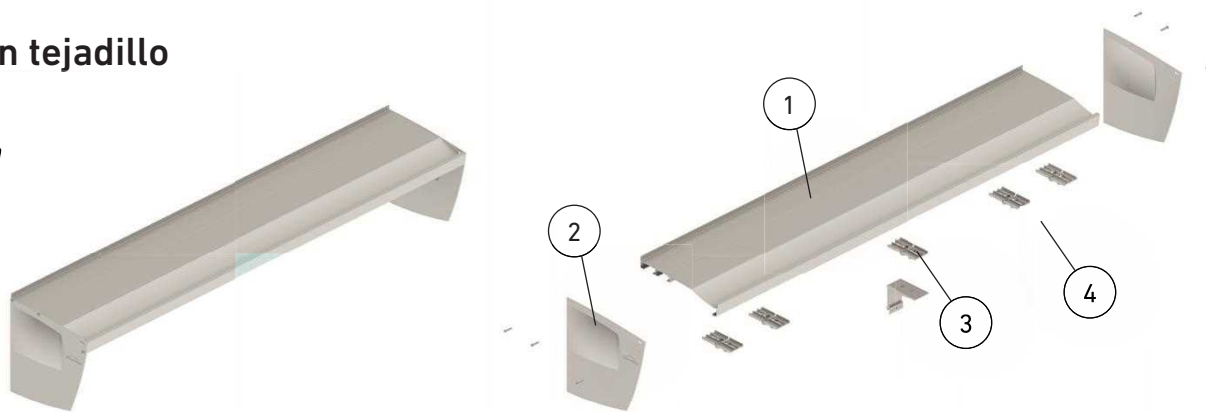

- **Espacio mínimo recomendado entre las tapas del tejadillo y los soportes ≥ 20 mm.**
- *Minimum space recommended between flat hood side caps and supports >20 mm.*
- *Espace minimum conseillé entre les couvercles du auvent et les supports >20 mm.*
- *Spazio minimo tra tappi del tettuccio e supporti ≥ 20 mm.*

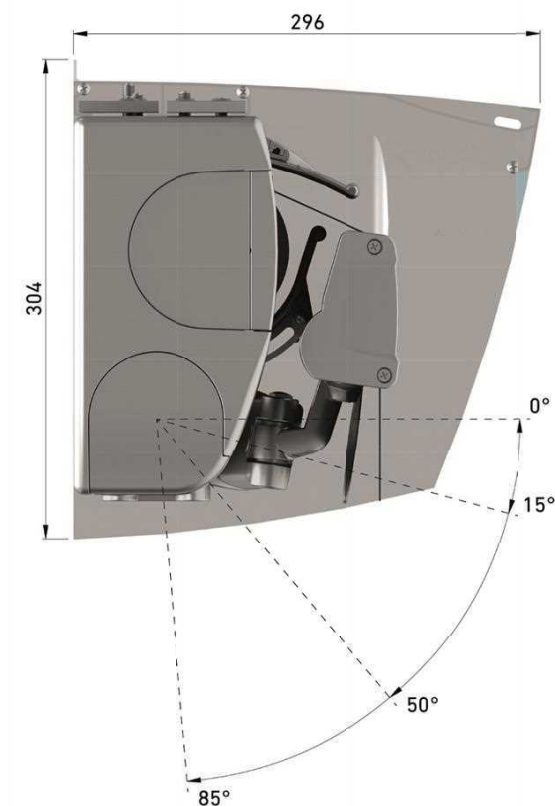

Inclinación máxima
Maximum slope • *Inclinaison maximale* • *Inclinazione massima*

Ángulos de inclinación

Slope angles

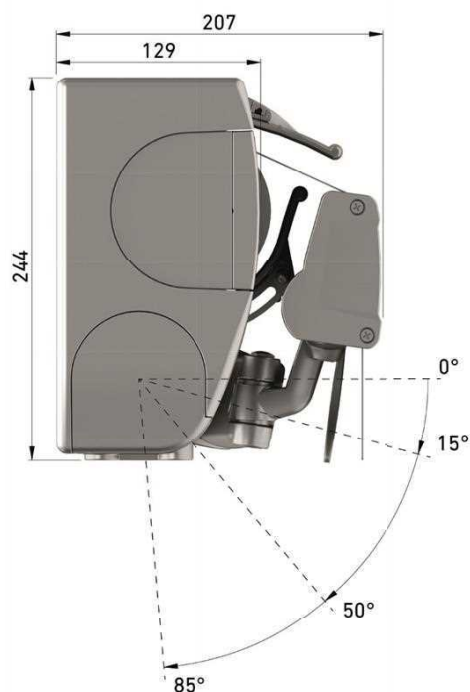

Inclinación máxima
Máximum slope
Inclinaison maximale
Inclinazione massima

Recomendaciones

Recommendations • Recommandations • Raccomandazioni

- **Recomendado hasta 6,00 m de línea x 3,00 m de salida, ó hasta 5,00 m de línea x 3,50 m de salida.**
 - **Posibilidad de montaje con cofre Spiral Premium y Tejadillo.**
 - **Montaje con máquina exterior, interior, a derecha o izquierda y con motor.**
 - **Posibilidad de montaje con Brazos Cruzados.**
 - **Con Brazos Cruzados, hasta 30° de inclinación.**
-
- *Recommended for up to 6.00 m width x 3.00 m projection, or up to 5.00 m width x 3.50 m projection.*
 - *Possible mounting with Spiral Premium box and Flat Hood.*
 - *Mounting with outside gear, inside gear, to the right or left side and with motor.*
 - *Assembly option with Crossed Arms.*
 - *With Crossed Arms, up to 30° slope.*
-
- *Conseillé jusqu'à 6,00 m de largeur x 3,00 m de projection ou 4,00 de largeur x 3,50 m de projection.*
 - *Possibilité de montage avec coffre Spiral Premium et Auvent.*
 - *Montage avec treuil extérieure, intérieure, à droite ou à gauche et avec moteur.*
 - *Possibilité de montage avec les bras croisés.*
 - *Avec les bras croisés, jusqu'à une inclinaison de 30°.*
-
- *Consigliato fino a 6,00 m di larghezza x 3,00 m di sporgenza o fino a 5,00 m di larghezza x 3,50 m di sporgenza.*
 - *Possibilità di montaggio con cassonetto Spiral Premium e Tettuccio.*
 - *Montaggio con arganello esteriore, interiore, a destra o sinistra e motore.*
 - *Possibilità di montaggio con bracci incrociati.*
 - *Con bracci incrociati, fino a 30° d'inclinazione.*

Ábaco de resistencia al viento

Wind resistance abacus

Abaque de résistance au vent

Abaco di resistenza al vento



NOTA: Las clases expuestas han sido obtenidas según las condiciones de ensayos descritos en los E.I.T. de Gaviota Simbac.

NOTE: The different classes have been fulfilled according to the described conditions at Gaviota Simbac initial tests.

NOTE: Le classement exposé a été obtenu suivant les conditions d'essais indiquées sur le manuel technique E.I.T. de Gaviota Simbac.

NOTA: Le classi esposte, sono state ottenute secondo le condizioni di prova descritte nel manuale E.I.T. di Gaviota Simbac.

EN-1933:1999
Resistencia al embolsamiento de agua <i>Resistance to water retention</i> <i>Résistance au ramassage d'eau</i> <i>Resistenza all'accumulo di acqua</i>
Clase 2

El toldo es capaz de evacuar el agua con una inclinación mínima de 14°.

The awning is able to evacuate water with a minimum slope of 14°.

Le store est capable d'évacuer l'eau avec une inclinaison minimum de 14°.

La tenda da sole è in grado di smaltire l'acqua con un'inclinazione minima di 14°.

EN-13561:2004 **Ábaco de resistencia al viento** • *Wind resistance selection abacus* • *Abaque de résistance au vent* • *Abaco resistenza al vento*

	2,00	2,50	3,00	3,50	4,00	4,50	5,00	5,50	6,00	L / S
	Clase 2	Clase 2	Clase 2	Clase 2	Clase 2	Clase 2	Clase 2	Clase 2	Clase 2	1,25
	Clase 2	Clase 2	Clase 2	Clase 2	Clase 2	Clase 2	Clase 2	Clase 2	Clase 2	1,50
	Clase 1*	Clase 2	Clase 2	Clase 2	Clase 2	Clase 2	Clase 2	Clase 2	Clase 2	1,75
	Clase 1*	Clase 2	Clase 2	Clase 2	Clase 2	Clase 2	Clase 2	Clase 2	Clase 2	2,00
	Clase 1*	Clase 1*	Clase 2	Clase 2	Clase 2	Clase 2	Clase 2	Clase 2	Clase 2	2,25
	Clase 1*	Clase 1*	Clase 2	Clase 2	Clase 2	Clase 2	Clase 2	Clase 2	Clase 2	2,50
	Clase 1*	Clase 1*	Clase 1*	Clase 2	Clase 2	Clase 2	Clase 2	Clase 2	Clase 2	2,75
	Clase 1*	Clase 1*	Clase 1*	Clase 1*	Clase 2	Clase 2	Clase 2	Clase 2	Clase 2	3,00
	IM	Clase 1*	Clase 1*	Clase 1*	Clase 2	Clase 2	Clase 2	Clase 1	Clase 1	3,25
	IM	Clase 1*	Clase 1*	Clase 1*	Clase 1*	Clase 2	Clase 2	Clase 1	Clase 1	3,50

***Montado con cruce de brazo** • **Mounted with crossed arms*
**Monté avec le bras croisé* • **Montato con bracci incrociati*

Resistencia al Viento • <i>Wind Resistance</i> • <i>Résistance au Vent</i> • <i>Resistenza al Vento</i>		
Clase • <i>Class</i> Clase • <i>Classe</i>	Velocidad Máxima Viento • <i>Maximum Wind Speed</i> Vélocité Maximale Vent • <i>Velocità Massima Vento</i>	Presión • <i>Pressure</i> Pression • <i>Pressione</i>
1	28 Km/h	40 N/m ²
2	38 Km/h	70 N/m ²
3	49 Km/h	110 N/m ²

Clase 1 • *Class 1* • *Clase 1* • *Classe 1*

Clase 2 • *Class 2* • *Clase 2* • *Classe 2*

Clase 3 • *Class 3* • *Clase 3* • *Classe 3*

IM Imposibilidad de montaje • *Impossible to assemble* • *Impossibilité de montage* • *Impossibile il montaggio*



Líneas mínimas

Minimum width • Largeur minimum • Larghezza minime

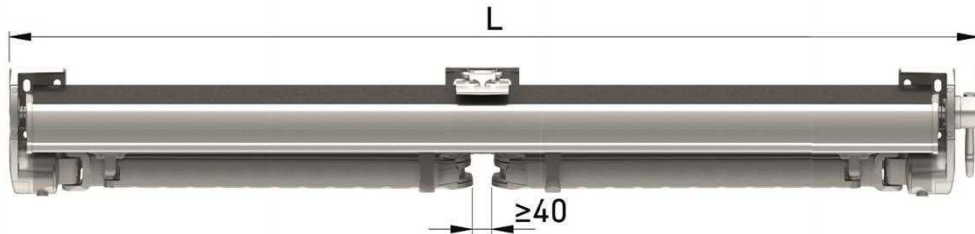

L para máquina por fuera con suplemento 80081660
L for gear outside with supplement 80081660
L pour treuil dehors avec supplément 80081660
L per arganello esteriore con supplemento 80081660

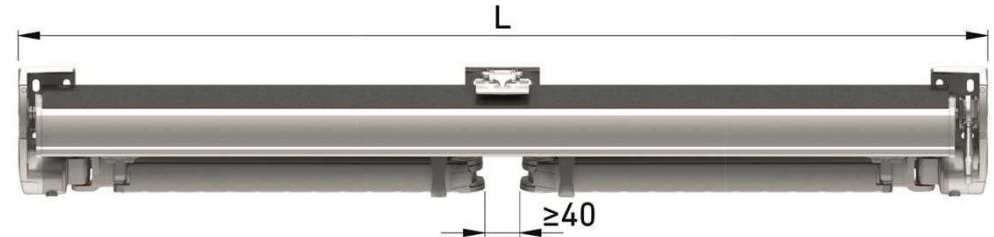

L para máquina por dentro ó motor
L for gear inside or motor
L pour treuil par dedans ou moteur
L per arganello interiore o motore

Con 40 mm de margen entre codos
With 40 mm margin between elbows
Avec 40 mm. de marge entre coudes
Con 40 mm. di margine tra gomiti

Líneas mínimas • Minimum width • Largeur minimum • Larghezza minime

Salida de brazos (m) <i>Arm projection (m)</i> <i>Projection de bras (m)</i> <i>Sporgenza bracci (m)</i>	Con máquina por fuera con suplemento 80081660 <i>With gear outside with supplement 80081660</i> <i>Avec treuil par dehors avec supplément 80081660</i> <i>Con arganello esteriore con supplemento 80081660</i>	Con máquina por dentro ó con mortor <i>With gear inside or motor</i> <i>Avec treuil par dedans ou moteur</i> <i>Con arganello interiore o motore</i>
1,50	1843	1795
1,75	2095	2047
2,00	2426	2378
2,25	2677	2630
2,50	2929	2881
2,75	3261	3213
3,00	3512	3464
3,25	3764	3716
3,50	4015	3968

Motorización • Motorization
Motorisation • Motorizzazione

		Posibilidad de montaje • Mounting possibility • Possibilit� de montage • Possibilit� di montaggio	
		Eje �70 con 2 Brazos • �70 axis with 2 Arms <i>Axe �70 � 2 bras • Rullo �70 con 2 Bracci</i>	Eje �78 con 2 Brazos • �78 axis with 2 Arms <i>Axe �78 � 2 bras • Rullo �78 con 2 Bracci</i>
Salida en metros <i>Arms projection in meters</i> <i>Proiection en m�tres</i> <i>Sporgenza in metri</i>	1.50	30 Nm	30 Nm
	1.75	30 Nm	40 Nm
	2.00	40 Nm	40 Nm
	2.25	40 Nm	40 Nm
	2.50	40 Nm	50 Nm
	2.75	50 Nm	50 Nm
	3.00	50 Nm	50 Nm
	3.25	50 Nm	80 Nm
	3.50	50 Nm	80 Nm

Descripción • Description Description • Descrizione

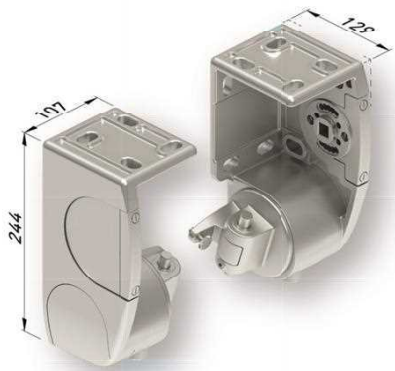

- Juego de soportes A1 Premium compuesto de casete y tornillos de ensamblaje.
- Set of Premium A1 supports.
- Jeu de supports A1 Premium.
- Kit supporti A1 Premium.

80081813



Descripción • Description Description • Descrizione

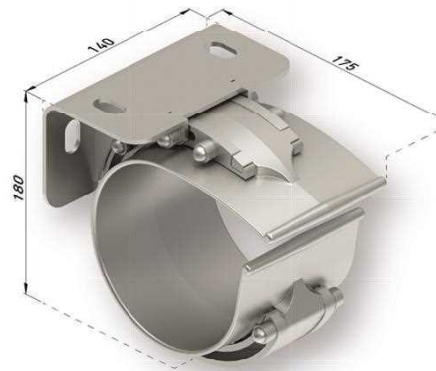

- Soporte central lira a pared/techo, regulable con tornillos de anclaje y fijación para sujeción de tubo y lona.
- Lyre type central wall/ceiling support, adjustable with fixing screws for tube and fabric.
- Support central lyre mur/couleur, réglable avec boulons d'ancrage et fixation pour tube et toile.
- Supporto a parete centrale lira A1 Premium.

80081697



Descripción • Description Description • Descrizione

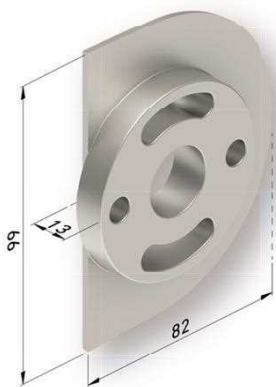

- Suplemento máquina exterior.
- External supplement for gear.
- Supplément treuil extérieur.
- Suplemento argano esteriore.

80081660



Descripción • Description Description • Descrizione

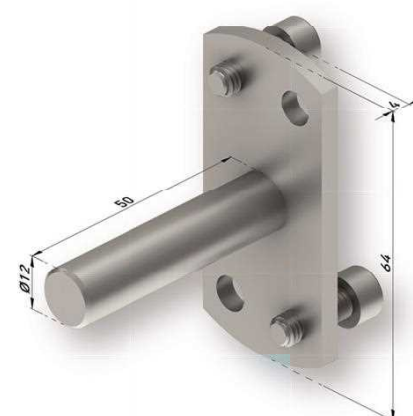

- Conjunto pletina para punto.
- Round pivot plate.
- Ensemble platine côté opposé.
- Piastrina con perno.

80081060



Descripción • Description
Description • Descrizione

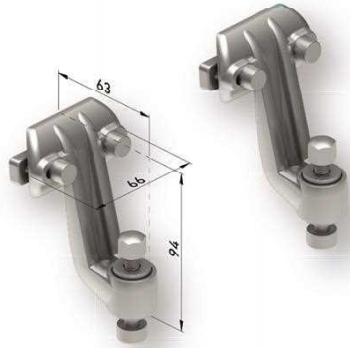

- **Juego de regletas frontales.**
- *Set of frontal adjustments.*
- *Fixations bras/barre de charge frontale.*
- *Set squadrette fissaggio frontale.*

80080875



Descripción • Description
Description • Descrizione



- **Juego de regletas inferiores.**
- *Set of lower adjustments.*
- *Fixations bras/barre de charge inférieure.*
- *Set squadrette fissaggio inferiore.*

80080885



Descripción • Description
Description • Descrizione

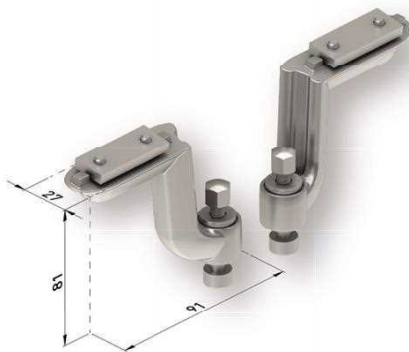

- **Juego de regletas laterales.**
- *Set of lateral adjustments.*
- *Fixations bras/barre de charge latérale.*
- *Set squadrette fissaggio laterali.*

80081662



Descripción • Description
Description • Descrizione

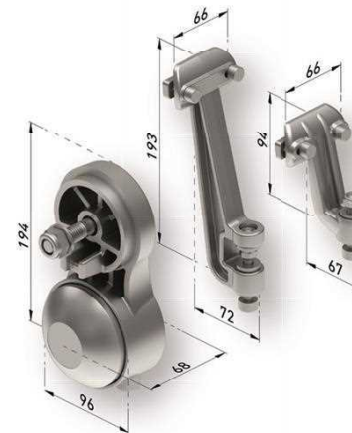

- **Kit para Brazo Cruzado Sistema A1 Premium con regletas frontales.**
- *Set for Premium A1 crossed arms system with frontal adjustments.*
- *Kit pour bras croisés avec fixations frontales.*
- *Kit per braccio incrociato con squadrette fissaggio braccio al terminale frontali.*

80081093



Descripción • Description Description • Descrizione

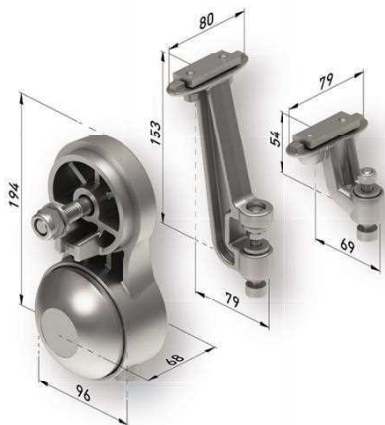

- **Kit para Brazo Cruzado Sistema A1 Premium con regletas inferiores.**
- *Set for Premium A1 crossed arms system with lower adjustments.*
- *Kit pour bras croisés avec fixations inférieures.*
- *Kit per braccio incrociato con squadrette fissaggio braccio al terminale inferiori.*

80081102



Descripción • Description Description • Descrizione

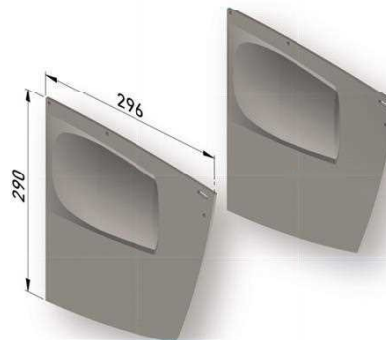

- **Tapas tejadillo V2 grandes.**
- *Set of big sides for V2 flat hood.*
- *Joues latérales d'auvent V2 grandes.*
- *Kit tappi tettuccio di copertura V2 grandi.*

80081321



Descripción • Description Description • Descrizione



- **Soporte superior tejadillo extrusión.**
- *Extruded flat hood upper support.*
- *Support auvent supérieur extrudé.*
- *Supporto sup. alluminio estruso per tettuccio.*

80080192



Descripción • Description Description • Descrizione

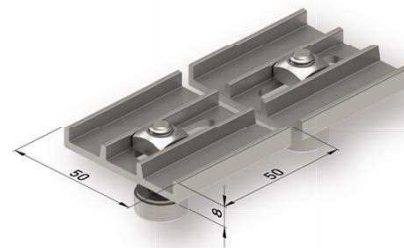

- **Juego regletas tejadillo para soporte techo/pared extrusión 80080192, con tapones blancos.**
- *Set of hood mounting plate for extruded wall/ceiling support 80080192, with white caps.*
- *Jeu de fixations d'auvent pour support extrudé coulé/mur 80080192 avec vis d'assemblage blancs.*
- *Kit piastrine alluminio estruso per supporto a tettuccio superiore 80080192 con viti.*

80080354



Descripción • Description
Description • Descrizione

- **Tejadillo monobloc V2.**
- *V2 monobloc flat hood.*
- *Auvent monobloc V2.*
- *Tettuccio di copertura V2.*



80081302



Descripción • Description
Description • Descrizione

- **Pivote tope barra de carga A1.**
- *Stopper pivot for A1 charge profile.*
- *Pivot arrêt barre de charge A1.*
- *Ferma braccio per barra terminale A1.*



80081800



Descripción • Description
Description • Descrizione

- **Puntal telescópico para barra de carga.**
- *Telescopic pole for front profile.*
- *Pied télescopique pour barre de charge.*
- *Supporto telescopico per profilo terminale.*



80081723



Descripción • Description
Description • Descrizione

- **Perfil canal Concept.**
- *Concept channel profile.*
- *Profilé canal Concept.*
- *Profilo canaletta Concept.*

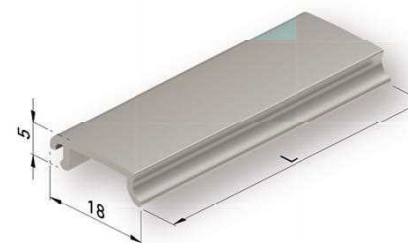

80131546

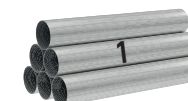

Descripción • Description Description • Descrizione

- **Juego de brazos invisibles Premium.**
- *Set of Premium retractable arms.*
- *Jeu de bras invisibles Premium.*
- *Kit bracci invisibili Premium.*



80080785



Descripción • Description Description • Descrizione

- **Juego de brazos invisibles Concept 350.**
- *Set of Premium retractable arms Concept 350.*
- *Jeu de bras invisibles Premium Concept 350.*
- *Kit bracci invisibili Premium Concept 350.*



80081670



Fuerza de 2 Brazos Premium • Strength of 2 Premium Arms Force de 2 bras Premium • Spinta di 2 bracci Premium

Salida • Projection Largeur • Sporgenza (m)	Fuerza • Strength Force • Spinta (Kg)	Fuerza 90° • 90° Strength Force 90° • Spinta 90° (Kg)
1,50	50,60	9,40
1,75	55,20	9,50
2,00	61,30	11,10
2,25	66,60	11,40
2,50	71,40	11,70
2,75	78,00	14,20
3,00	83,70	14,40
3,25	87,70	14,70
3,50	91,90	14,90

Fuerza de 2 Brazos Concept • Strength of 2 Concept Arms Force de 2 bras Concept • Spinta di 2 bracci Concept

Salida • Projection Largeur • Sporgenza (m)	Fuerza • Strength Force • Spinta (Kg)
1,50	50,50
1,75	55,10
2,00	61,20
2,25	66,50
2,50	71,30
2,75	78,00
3,00	83,60
3,25	87,70
3,50	91,70

Descripción • Description
Description • Descrizione



- **Kit de iluminación brazos Concept.**
- *Concept arm lighting kit.*
- *Kit d'illumination bras Concept.*
- *Kit illuminazione bracci Concept.*

80081913



Descripción • Description
Description • Descrizione



- **Fuente de alimentación 24V / 60W.**
- *24V / 60W Power supply.*
- *Source d'alimentation 24V / 60W.*
- *Alimentazione 24V / 60W.*

80081864



Descripción • Description
Description • Descrizione



- **Fuente de alimentación con dimmer 24V / 60W.**
- *24V / 60W Power supply with dimmer.*
- *Source d'alimentation avec dimmer 24V / 60W.*
- *Alimentazione con dimmer 24V / 60W.*

80082025





A1 PREMIUM



Descripción • Description Description • Descrizione	L/m	Blanco White Blanc Bianco	Negro Texturado Black Textured Noir Texturé Nero Texturato	Plata Texturado Silver Textured Argent Texturé Argento Texturato	Bronce Texturado Bronze Textured Bronze Texturé Bronzo Texturato	Gris 7011 Grey 7011 Gris 7011 Grigio 7011	Marron 8014 Brown 8014 Brun 8014 Marrone 8014	Beige 1013	Gris 7016 Texturado Grey 7016 Textured Grey 7016 Texturé Grigio 7016 Texturato	Ral habitual • especial Regular • Special Ral Ral habituel • spécial Ral abituale • speciale
--	-----	------------------------------------	---	---	---	--	--	------------	---	---

Juego de soportes A1 Premium compuesto de casete y tornillos de ensamblaje • Set of Premium A1 supports <i>Jeu de supports A1 Premium • Kit supporti A1 Premium</i>		80081813	80081814	80081815	80081816	80081817	80081818	80081819	80082171	80081820
Soporte central lira pared/techo A1 Premium • Lyre type central wall/ceiling support, adjustable with fixing screws for tube and fabric • Support central lyre mur/coulé, réglable avec boulons d'ancrage et fixation pour tube et toile <i>Supporto a parete centrale lira A1 Premium</i>		80081697	80081698	80081699	80081700	80081701	80081702	80081703		80081704
Suplemento máquina exterior • External supplement for gear <i>Supplément treuil extérieur • Supplimento argano esteriore</i>		80081660	80081661							
Juego de regletas frontales • Set of frontal adjustments <i>Fixations bras/barre de charge frontale • Set squadrette fissaggio frontale</i>		80080875	80080877	80080876	80080878	80080883	80081177	80080882	80082162	80080884
Juego de regletas inferiores • Set of lower adjustments <i>Fixations bras/barre de charge inférieure • Set squadrette fissaggio inferiore</i>		80080885	80080887	80080886	80080888	80080893	80081179	80080892	80082165	80080894
Juego de regletas laterales • Set of lateral adjustments <i>Fixations bras/barre de charge latérale • Set squadrette fissaggio laterali</i>		80081662	80081663	80081664	80081665	80081666	80081667	80081668		80081669
Kit para Brazo Cruzado Sistema A1 Premium con regletas frontales <i>Set for Premium A1 crossed arms system with frontal adjustments Kit pour bras croisés avec fixations frontales Kit per braccio incrociato con squadrette fissaggio braccio al terminale frontali</i>		80081093	80081094	80081095	80081096	80081100	80081184	80081099		80081101
Kit para Brazo Cruzado Sistema A1 Premium con regletas inferiores <i>Set for Premium A1 crossed arms system with lower adjustments Kit pour bras croisés avec fixations inférieures Kit per braccio incrociato con squadrette fissaggio braccio al terminale inferiori</i>		80081102	80081103	80081104	80081105	80081109	80081185	80081108		80081110
Tapas tejadillo V2 grandes • Set of big sides for V2 flat hood <i>Joues latérales d'auvent V2 grandes • Kit tappi tettuccio di copertura V2 grandi</i>		80081321	80081322	80081323	80081324	80081325	80081326	80081375		80081327
Soporte superior tejadillo extrusión • Extruded flat hood upper support <i>Support auvent supérieur extrudé Supporto sup. alluminio estruso per tettuccio</i>		80080192	80080194	80080193	80080420			80080291		80080498